



ECMA-E11310ES 無煞車

ECMA-E11310FS 有煞車



ASD-A2-1021B

搭配線材



編碼器連接線-可客製化長度



動力連接線-可客製化長度



伺服連接線-可客製化長度

1000W 馬達

機型 ECMA	E113				E118		F118	G113		
	05	10	15	20	20	30	30	03	06	09
額定功率 (kW)	0.5	1.0	1.5	2.0	2.0	3.0	3.0	0.3	0.6	0.9
額定扭矩 (N-m)	2.39	4.77	7.16	9.55	9.55	14.32	19.10	2.86	5.73	8.59
最大扭矩 (N-m)	7.16	14.3	21.48	28.65	28.65	42.97	57.29	8.59	17.19	21.48
額定轉速 (r/min)	2000						1500	1000		
最高轉速 (r/min)	3000							2000		
額定電流 (A)	2.9	5.6	8.3	11.01	11.22	16.1	19.4	2.5	4.8	7.5
瞬時最大電流 (A)	8.7	16.8	24.9	33.03	33.66	48.3	58.2	7.5	14.4	22.5
每秒最大功率 (kW/s)	7.0	27.1	45.9	62.5	26.3	37.3	66.4	10.0	39.0	66.0
轉子慣量 (kg-m ²)	8.17E-4	8.41E-4	11.18E-4	14.59E-4	34.68E-4	54.95E-4	54.95E-4	8.17E-4	8.41E-4	11.18E-4
機械常數 (ms)	1.91	1.51	1.10	0.96	1.62	1.06	1.28	1.84	1.40	1.06
扭矩常數-KT (N-m/A)	0.83	0.85	0.87	0.87	0.85	0.89	0.98	1.15	1.19	1.15
電壓常數-KE (mV/(r/min))	30.9	31.9	31.8	31.8	31.4	32	35	42.5	43.8	41.6
電機阻抗 (Ohm)	0.57	0.47	0.26	0.174	0.119	0.052	0.077	1.06	0.82	0.43
電機感抗 (mH)	7.39	5.99	4.01	2.76	2.84	1.38	1.27	14.29	11.12	6.97
電氣常數 (ms)	12.96	12.88	15.31	15.86	23.87	26.39	16.51	13.55	13.50	16.06
絕緣等級	A 級 (UL) , B 級 (CE)									
絕緣阻抗	100MW , DC 500V以上									
絕緣耐壓	AC 1500 V, 60 秒									
重量 - 不帶煞車 (kg)	6.8	7	7.5	7.8	13.5	18.5	18.5	6.8	7	7.5
重量 - 帶煞車 (kg)	8.2	8.4	8.9	9.2	17.5	22.5	22.5	8.2	8.4	8.9
徑向最大荷重 (N)	490	490	490	490	1176	1470	1470	490	490	490
軸向最大荷重 (N)	98	98	98	98	490	490	490	98	98	98
每秒最大功率(kW/s)含煞車	6.4	24.9	43.1	59.7	24.1	35.9	63.9	9.2	35.9	62.1
轉子慣量 (kg.m) 含煞車	8.94-E-4	9.14-E-4	11.90-E-4	15.88-E-4	37.86-E-4	57.06-E-4	57.06-E-4	8.94-E-4	9.14-E-4	11.9-E-4
機械常數 (ms) 含煞車	2.07	1.64	1.19	1.05	1.77	1.10	1.33	2.0	1.51	1.13
剎車保持扭矩 [Nt-m (min)]	16.5	16.5	16.5	16.5	25	25	25	16.5	16.5	16.5
剎車消耗功率 (at 20C) [W]	21.0	21.0	21.0	21.0	31.1	31.1	31.1	21.0	21.0	21.0
剎車釋放時間 [ms (Max)]	5.0	5.0	5.0	5.0	5.0	5.0	5.0	5.0	5.0	5.0
剎車吸引時間 [ms (Max)]	25.0	25.0	25.0	25.0	25.0	25.0	25.0	25.0	25.0	25.0
振動級數 (mm)	15									



➤ 驅動器尺寸

750W / **1.0kW** / 1.5kW

重量
2.0 (4.4)

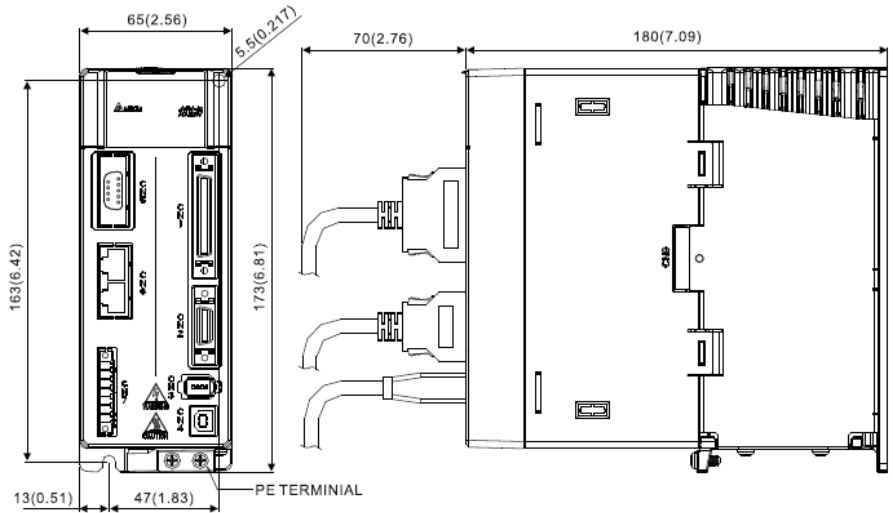

➤ 外觀尺寸

● ECMA 系列馬達 100 框號 (含) 以上系列 (Units : mm)

➤ T-N 曲線

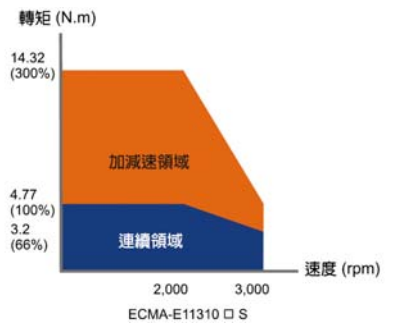
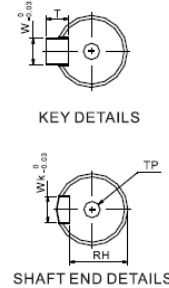
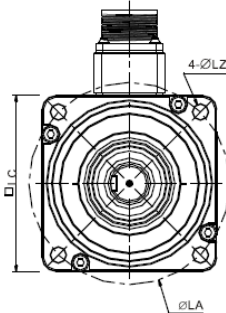
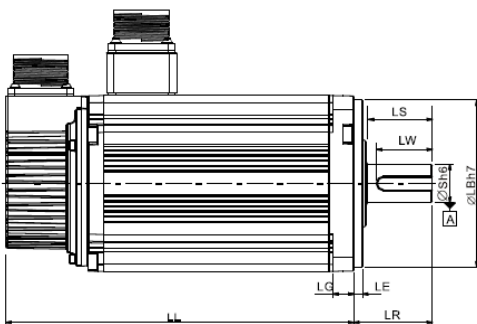

1000W 馬達

Model	E11310□S	E11315□S	C11020□S	E11320□7	E11820□S	E11830□S	F11830□S
LC	130	130	100	130	180	180	180
LZ	9	9	9	9	13.5	13.5	13.5
LA	145	145	115	145	200	200	200
S	22	22	22	22	35	35	35
LB	110	110	95	110	114.3	114.3	114.3
LL(不帶煞車)	147.5	167.5	199	187.5	169	202.1	202.1
LL(帶煞車)	183.5	202	226	216	203.1	235.3	235.1
LS	47	47	37	47	73	73	73
LR	55	55	45	55	79	79	79
LE	6	6	5	6	4	4	4
LG	11.5	11.5	12	11.5	20	20	20
LW	36	36	32	36	63	63	63
RH	18	18	18	18	30	30	30
WK	8	8	8	8	10	10	10
W	8	8	8	8	10	10	10
T	7	7	7	7	8	8	8
TP	M6xP1 Depth:20mm	M6xP1 Depth:20mm	M6xP1 Depth:20mm	M6xP1 Depth:20mm	M12xP1.75 Depth:25mm	M12xP1.75 Depth:25mm	M12xP1.75 Depth:25mm