



MR-J4-500A



HG-SR502K 無煞車

HG-SR502BK 有煞車

5000W

HG-SR2000r/min系列(中慣性、中容量)(200V级别)规格

旋转型伺服电机		HG-SR	52(B)	102(B)	152(B)	202(B)	352(B)	502(B)	702(B)
对应的伺服放大器产品型号		MR-J4- MR-J4W_-	请参照本产品目录P.2-4中的“旋转型伺服电机与伺服放大器的组合”。						
电源设备容量 ¹		[kVA]	1.0	1.7	2.5	3.5	5.5	7.5	10
连续特性	额定输出	[kW]	0.5	1.0	1.5	2.0	3.5	5.0	7.0
	额定转矩 ^(注3)	[N·m]	2.4	4.8	7.2	9.5	16.7	23.9	33.4
最大转矩		[N·m]	7.2	14.3	21.5	28.6	50.1	71.6	100
额定转速		[r/min]	2000						
最大转速		[r/min]	3000						
瞬时容许转速		[r/min]	3450						
连续额定转矩时的功率	标准	[kW/s]	7.85	19.7	32.1	19.5	35.5	57.2	74.0
	带电磁制动器	[kW/s]	6.01	16.5	28.2	16.1	31.7	52.3	69.4
额定电量		[A]	2.9	5.6	9.4	9.6	14	22	26
最大电量		[A]	9.0	17	29	31	45	70	83
再生制动频率 ²	MR-J4-	[次/分]	31	38	139	47	28	29	25
	MR-J4W_-	[次/分]	154	96	-	-	-	-	-
惯量J	标准	[× 10 ⁻⁴ kg·m ²]	7.26	11.6	16.0	46.8	78.6	99.7	151
	带电磁制动器	[× 10 ⁻⁴ kg·m ²]	9.48	13.8	18.2	56.5	88.2	109	161
推荐负载惯量比 ^(注1)			15倍以下	17倍以下			15倍以下		
速度·位置编码器			绝对位置·增量共用22bit编码器 (伺服电机每转的分辨率: 4194304Pulses/rev)						
油封			带油封						
耐热级别			155 (F)						
构造			全闭自冷(保护等级: IP67) ^(注2)						
环境条件 ³	周围温度		0℃~40℃(无冻结)、保存: -15℃~70℃(无冻结)						
	周围湿度		80%RH以下(无结露)、保存: 90%RH以下(无结露)						
	空气环境		室内(无阳光直射的地方)、无腐蚀性气体、可燃性气体、油雾及灰尘的场所						
	海拔		海拔1000m以下						
振动 ⁴			X: 24.5 m/s ² Y: 24.5 m/s ²			X: 24.5 m/s ² Y: 49 m/s ²		X: 24.5 m/s ² Y: 29.4 m/s ²	
振动等级			V10 ⁶						
海外标准			请参照本产品目录P.30的“对海外标准·规定”						
轴的容许负载 ⁵	L	[mm]	55	55	55	79	79	79	79
	径向	[N]	980	980	980	2058	2058	2058	2058
	推力	[N]	490	490	490	980	980	980	980
质量	标准	[kg]	4.8	6.2	7.3	11	16	20	27
	带电磁制动器	[kg]	6.7	8.2	9.3	17	22	26	33

驱动器尺寸

MR-J4-350A(-RJ) (注1)

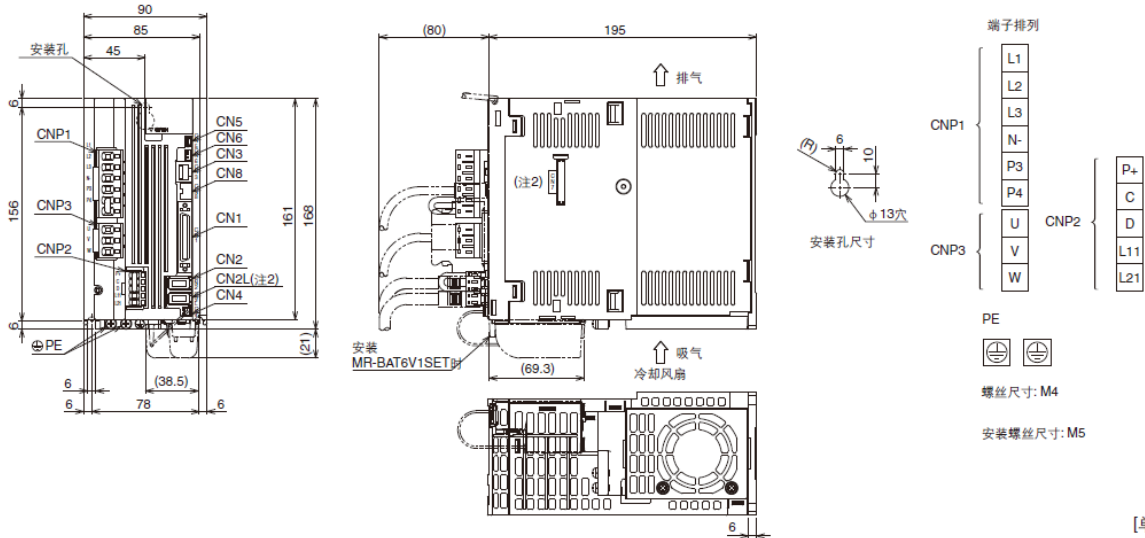

外觀尺寸

- HG-SR121(B), HG-SR201(B), HG-SR301(B), HG-SR421(B)
- HG-SR202(B), HG-SR352(B), **HG-SR502(B)**, HG-SR702(B)
- HG-SR2024(B), HG-SR3524(B), HG-SR5024(B), HG-SR7024(B)

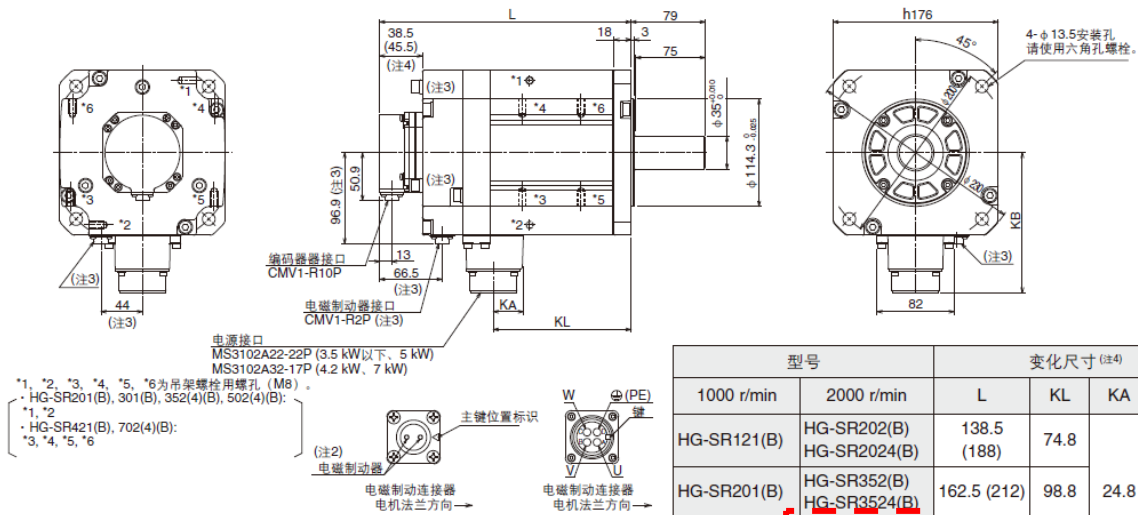

型号		变化尺寸(注4)			
1000 r/min	2000 r/min	L	KL	KA	KB
HG-SR121(B)	HG-SR202(B) HG-SR2024(B)	138.5 (188)	74.8		
HG-SR201(B)	HG-SR352(B) HG-SR3524(B)	162.5 (212)	98.8	24.8	140.9
HG-SR301(B)	HG-SR502(B) HG-SR5024(B)	178.5 (228)	114.8		
HG-SR421(B)	HG-SR702(B) HG-SR7024(B)	218.5 (268)	146.8	32	149.1

HG-SR502(B) (注1)

T-N 曲线

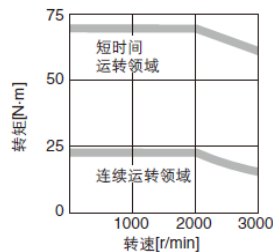

HG-SR 2000 r/min Series (200 V Class) Special Shaft End Specifications

Motors with the following specifications are also available.

Key shaft (without key) ^(Note 1, 2)

Model	Variable dimensions								
	S	R	Q	W	QK	QL	U	r	Y
HG-SR52(B)K, 102(B)K, 152(B)K	24h6	55	50	8 ⁰ _{-0.036}	36	5	4 ^{+0.2} ₀	4	M8 screw Depth: 20
HG-SR202(B)K, 352(B)K, 502(B)K, 702(B)K	35 ^{+0.010} ₀	79	75	10 ⁰ _{-0.036}	55	5	5 ^{+0.2} ₀	5	

Notes: 1. Do not use servo motors with key shafts for applications that start/stop frequently because the key shaft may break and cause an accident.

2. A key is not supplied with the servo motor. The key shall be installed by the user.

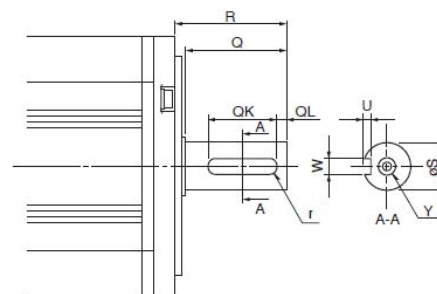

[Unit: mm]