



MR-J4-40A



HG-KR43K 無煞車

HG-KR43BK 有煞車

HG-KR系列(低慣性、小容量)规格

400W

转型伺服电机		HG-KR	053(B)	13(B)	23(B)	43(B)	73(B)
对应的伺服放大器产品型号		MR-J4- MR-J4W_-	请参照本产品目录中p.2-3中转型伺服电机和伺服放大器的组合(200V级别)。				
电源设备容量 ¹		[kVA]	0.3	0.3	0.5	0.9	1.3
连续特性	额定输出	[W]	50	100	200	400	750
	额定转矩(注3)	[N·m]	0.16	0.32	0.64	1.3	2.4
最大转矩		[N·m]	0.56	1.1	2.2	4.5	8.4
额定转速		[r/min]	3000				
最大转速		[r/min]	6000				
瞬时容许转速		[r/min]	6900				
连续额定转矩时的功率	标准	[kW/s]	5.63	13.0	18.3	43.7	45.2
	带电磁制动器	[kW/s]	5.37	12.1	16.7	41.3	41.6
额定电流		[A]	0.9	0.8	1.3	2.6	4.8
最大电流		[A]	3.2	2.5	4.6	9.1	17
再生制动频率 ²	MR-J4-	[次/分]	(注4)	(注4)	453	268	157
	MR-J4W_-	[次/分]	2500	1350	451	268	393
惯量J	标准	[× 10 ⁻⁴ kg·m ²]	0.0450	0.0777	0.221	0.371	1.26
	带电磁制动器	[× 10 ⁻⁴ kg·m ²]	0.0472	0.0837	0.243	0.393	1.37
推荐负载惯量比(注1)			17倍以下		26倍以下	25倍以下	17倍以下
速度·位置编码器			绝对位置·增量共用22bit编码器 (伺服电机每转的分辨率: 4194304Pulses/rev)				
油封			无油封	带油封。			
耐热级别			130 (B)				
构造			全闭自冷(保护等级: IP65) ^(注2)				
环境条件 ³	周围温度		0℃~40℃(无冻结)、保存: -15℃~70℃(无冻结)				
	周围湿度		80%RH以下(无结露)、保存: 90%RH以下(无结露)				
	空气环境		室内(无阳光直射的地方)、无腐蚀性气体、可燃性气体、油雾及灰尘的场所				
	海拔		海拔1000m以下				
振动等级			X: 49 m/s ² Y: 49 m/s ²				
海外标准			V10 ⁶				
海外标准			请参照本产品目录P.30的“对海外标准·规定”。				
轴的容许负载 ⁵	L	[mm]	25	25	30	30	40
	径向	[N]	88	88	245	245	392
	推力	[N]	59	59	98	98	147
质量	标准	[kg]	0.34	0.54	0.91	1.4	2.8
	带电磁制动器	[kg]	0.54	0.74	1.3	1.8	3.8



➤ 驅動器尺寸

- MR-J4-40A (Note 1)
- MR-J4-60A (Note 1)

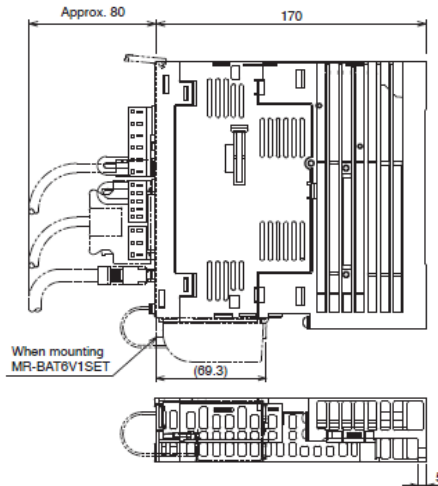
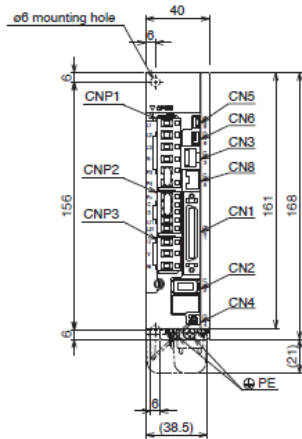

Terminal arrangement

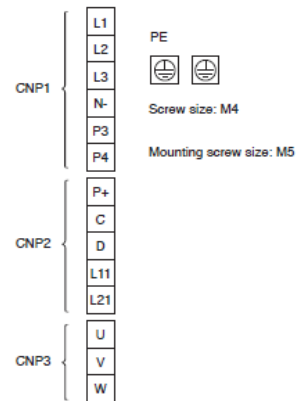

[Unit: mm]

➤ 外觀尺寸

- HG-KR23(B), HG-KR43(B)
- HG-MR23(B), HG-MR43(B)

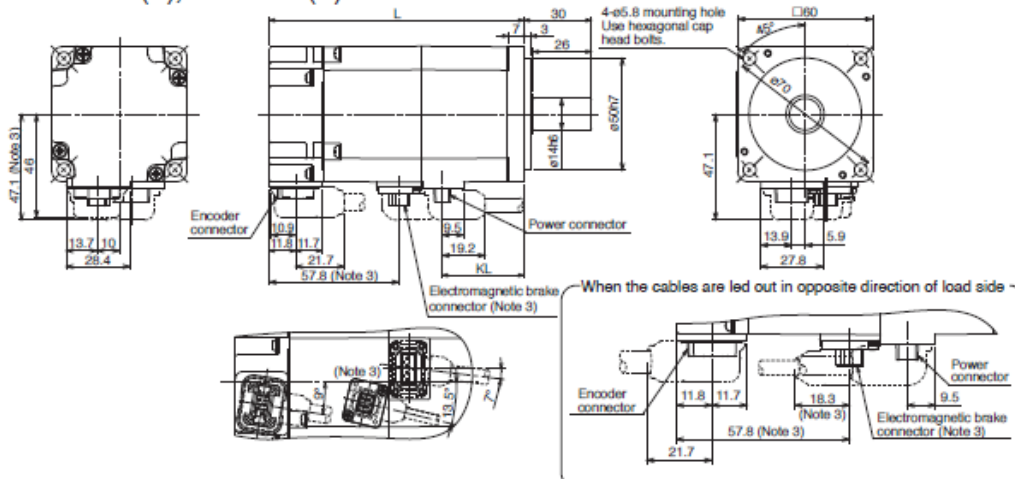

Power connector



Pin No.	Signal name
1	⊕ (PE)
2	U
3	V
4	W

Electromagnetic brake connector (Note 2)



Pin No.	Signal name
1	B1
2	B2

Model	Variable dimensions (Note 4)	
	L	KL
HG-KR23(B)	76.6	36.4
HG-MR23(B)	(113.4)	
HG-KR43(B)	98.3	58.1
HG-MR43(B)	(135.1)	

[Unit: mm]



T-N 曲線

HG-KR43(B) (Note 1, 2, 3, 4)

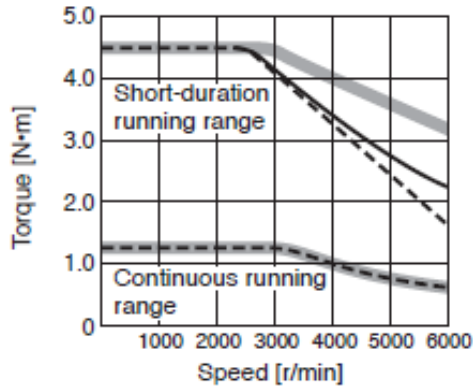

Key shaft (with key) (Note 1, 2): 200 W, 400 W, and 750 W

Model	Variable dimensions								
	T	S	R	Q	W	QK	QL	U	Y
HG-KR23(B)K, 43(B)K	5	14h6	30	26	5	20	3	3	M4 screw Depth: 15
HG-KR73(B)K	6	19h6	40	36	6	25	5	3.5	M5 screw Depth: 20

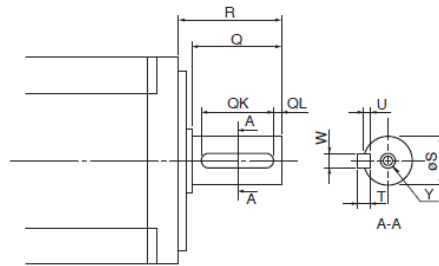

[Unit: mm]